



Powermatrix 106 CSB

**MASTERWORK**

# Powermatrix 106 CSB

The Powermatrix 106 CSB is the new professional die-cutting machine of the Heidelberg-Family. This blanking machine is especially designed for the industrial packaging producer.

Whether packaging for cosmetics, pharmaceuticals, health care, cigarettes or food: due to the high flexibility the Powermatrix offers plenty of scope and the easy machine handling and the big range of materials cover all needs.

Company structures which work with numerous short job lengths profit from the remarkable easy operation of the machine and the short change over times. The short change over times result in the first instance from the intelligent solutions within the single machine stations.

For enterprises with long job lengths the Powermatrix 106 CSB scores primarily with the automatic non-stop operation, the full logistic solution from feeder to delivery and from the reliable and precise

operation method. Beside the register system for the gripper bars, the new MasterSet is a further characteristic for the precise operation. The new MasterSet is an optical contactless sheet aligning system in the feed station.

The GS seal verifies that the machine underwent rigorous testing at the factory and complies with all safety standards as required by the German Association of Professional Printers (Berufsgenossenschaft Druck und Papierverarbeitung).

The Powermatrix 106 CSB is a product of Heidelberg: sold, serviced and supported by the largest sales and service force in the industry. The machine is installed, trained and supported by qualified local service technicians of Heidelberg. The legendary support of Heidelberg extends as well into the spare parts. Through its worldwide network of warehouses in Germany, the United States, Japan and Hong-Kong, spare parts will be shipped from the location that offers the soonest arrival time.



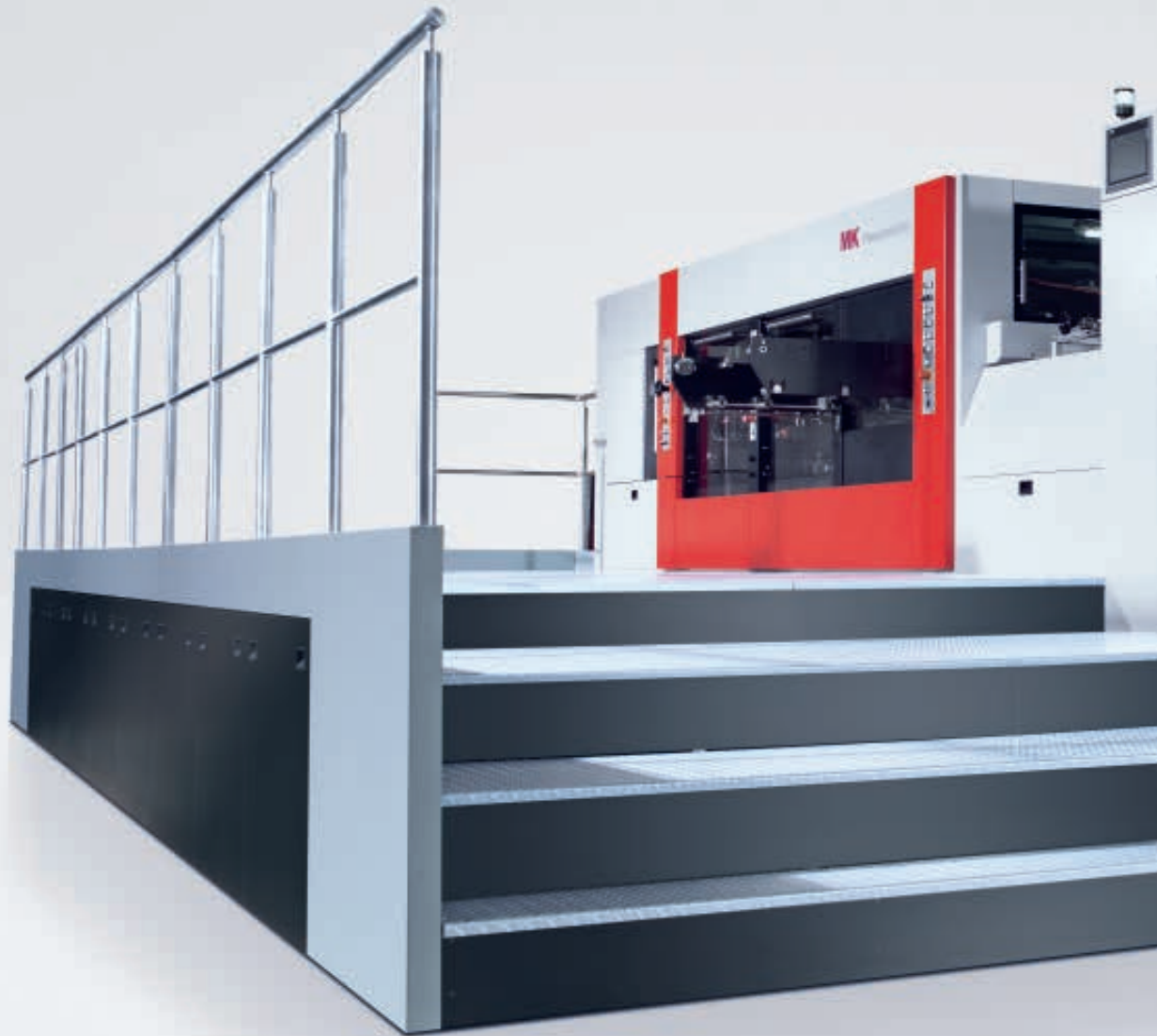

## Good from start to finish

The Powermatrix 106 CSB is ideal aligned to the requirements of the user. Tools can be changed easily in a convenient way and all operating elements are ergonomically optimized and arranged to give a clear overview.

For a precise sheet alignment in and across the sheet running direction, the optional MasterSet is available. Due to several camera systems and its unique functionality, the MasterSet doesn't need any mechanical front or side lays. The alignment happens "on the fly" and realizes a high register accuracy and less stops at the feed station.

The reference for the sheet aligning process is the sheet edge, printed marks or the print. The two last mentioned methods ensure that the print will be aligned and not only the sheet.

The operation of the Powermatrix 106 CSB is easy to learn and furthermore the basic machine is well equipped. This results into short make-ready times. The basic machine is equipped with all quick lock frames and systems, which are necessary for the three main stations. In addition the fine adjustment system for the cutting plate and the non-stop-operation are part of the standard scope.

To prepare jobs outside of the machine, while another job is running, an optional chase changer and/or a pre-make-ready table for stripping tools are available. Another machine highlight is the sampling function. This function allows checking the sheet quality without interrupting the production. At the push of a button the operator can remove a cut and stripped sheet during the ongoing production.

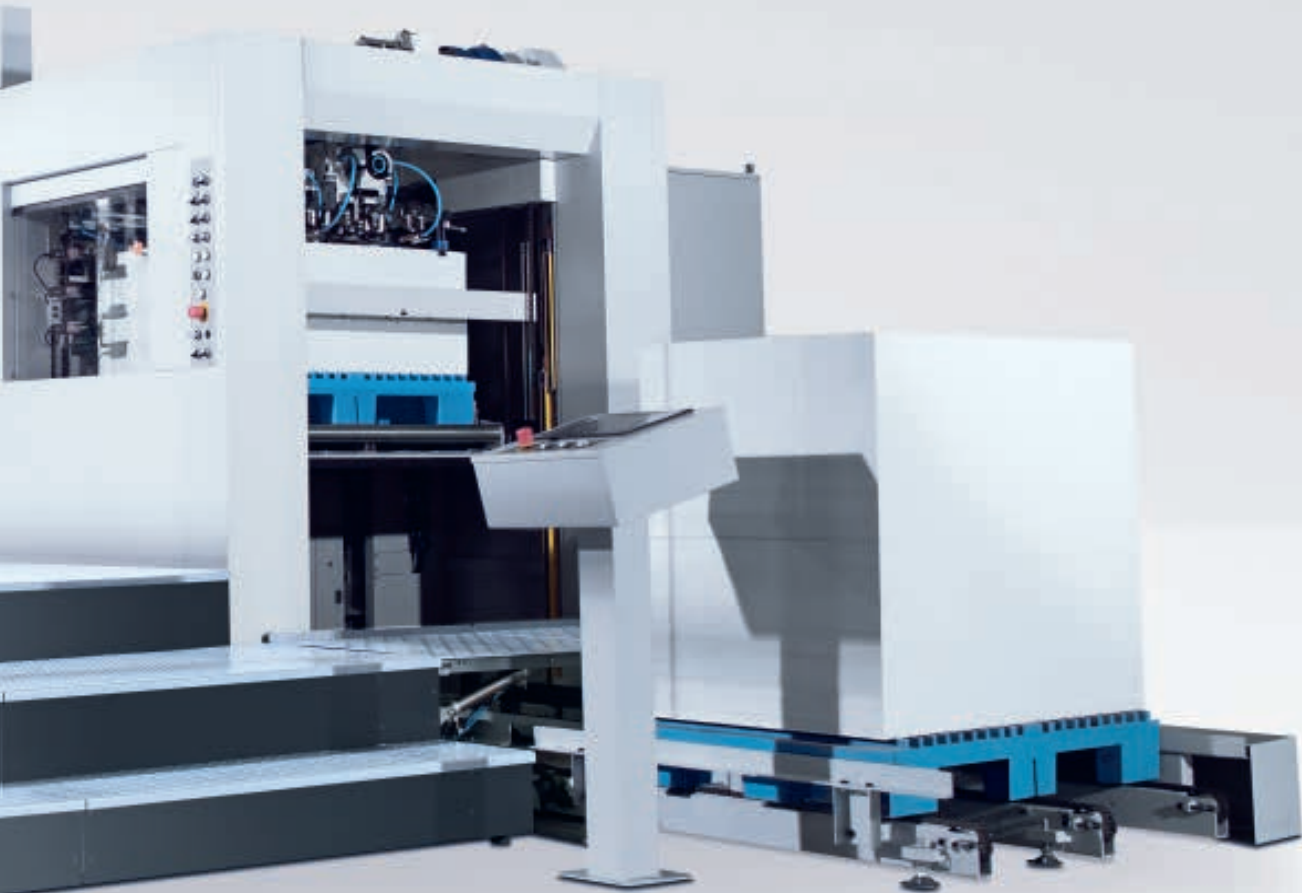

## Technical Data

### Suitable material:

- Paper (min.) 90 g/m<sup>2</sup>
- Carton Board (max.) 2,000 g/m<sup>2</sup>
- Corrugated Board (max.) 4 mm

### Performance data:

- Sheet size (max.) 760 x 1,060 mm
- Sheet size (min.) 350 x 400 mm
- Cutting pressure (max.) 2.6 MN / 260 t
- Machine speed (max.) 8,000 B/h

### Pile heights (incl. Pallet):

- Feeder pile height (max.)
  - w/o non-stop 1,500 mm
  - in non-stop operation 1,200 mm
- Delivery pile height (max.) 1,200 mm



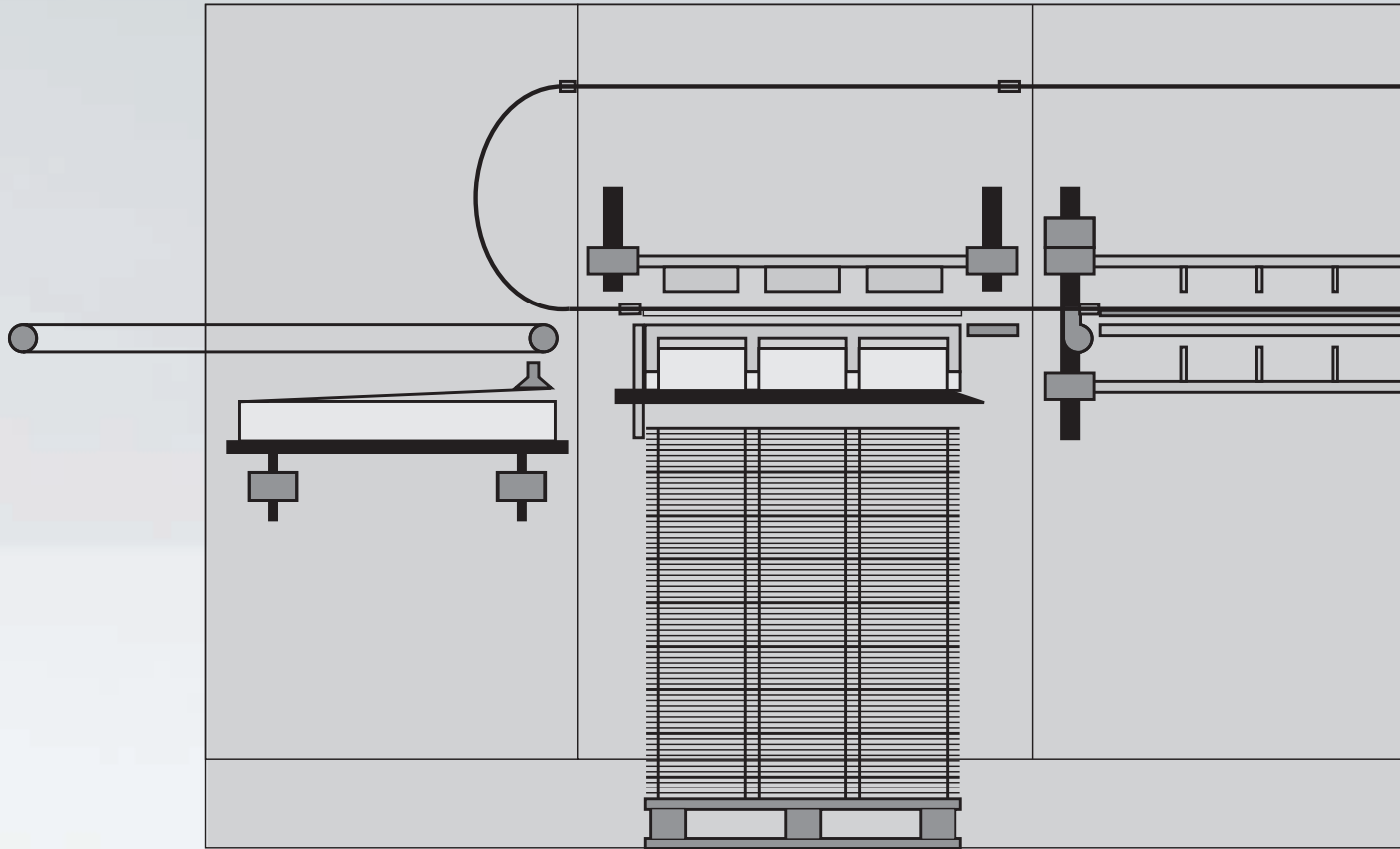

The machine shown is a sample configuration. Some of the equipment features mentioned are optional.



### Test Sheet Removal

- Quality control during production
- No need to stop the production process
- Sheet will be cut and stripped and then provided via the waste belt conveyor

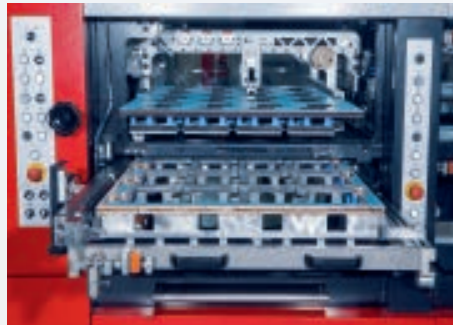

### Blanking Station

- Integrated quick lock systems for all tools
- Fine adjustment of tools with position indicators
- Non-stop operation
- Automatic pallet change system
- Tie sheet inserter
- Vacuum bar

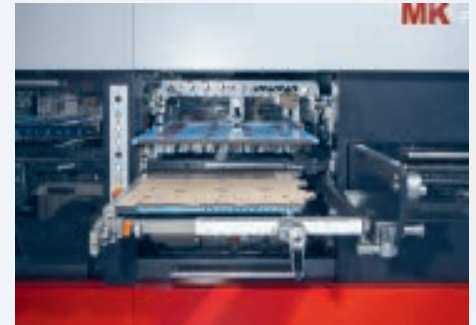

### Stripping Station

- Register system
- Integrated quick lock systems for all tools (top, middle, bottom)
- Fine adjustment of tools with position indicators
- Test sheet removal
- Pre-make-ready table (optional)

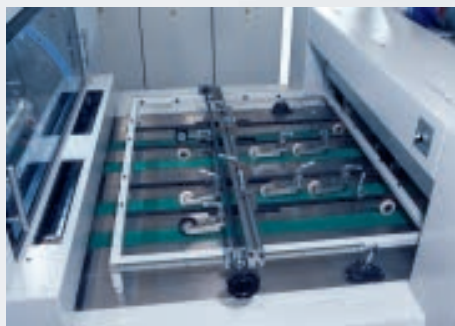
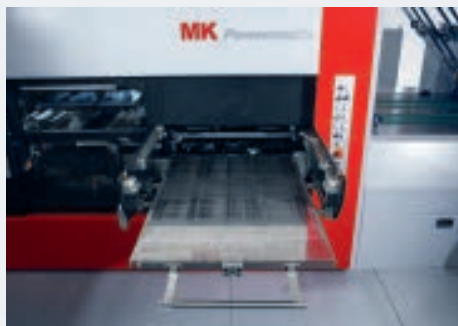
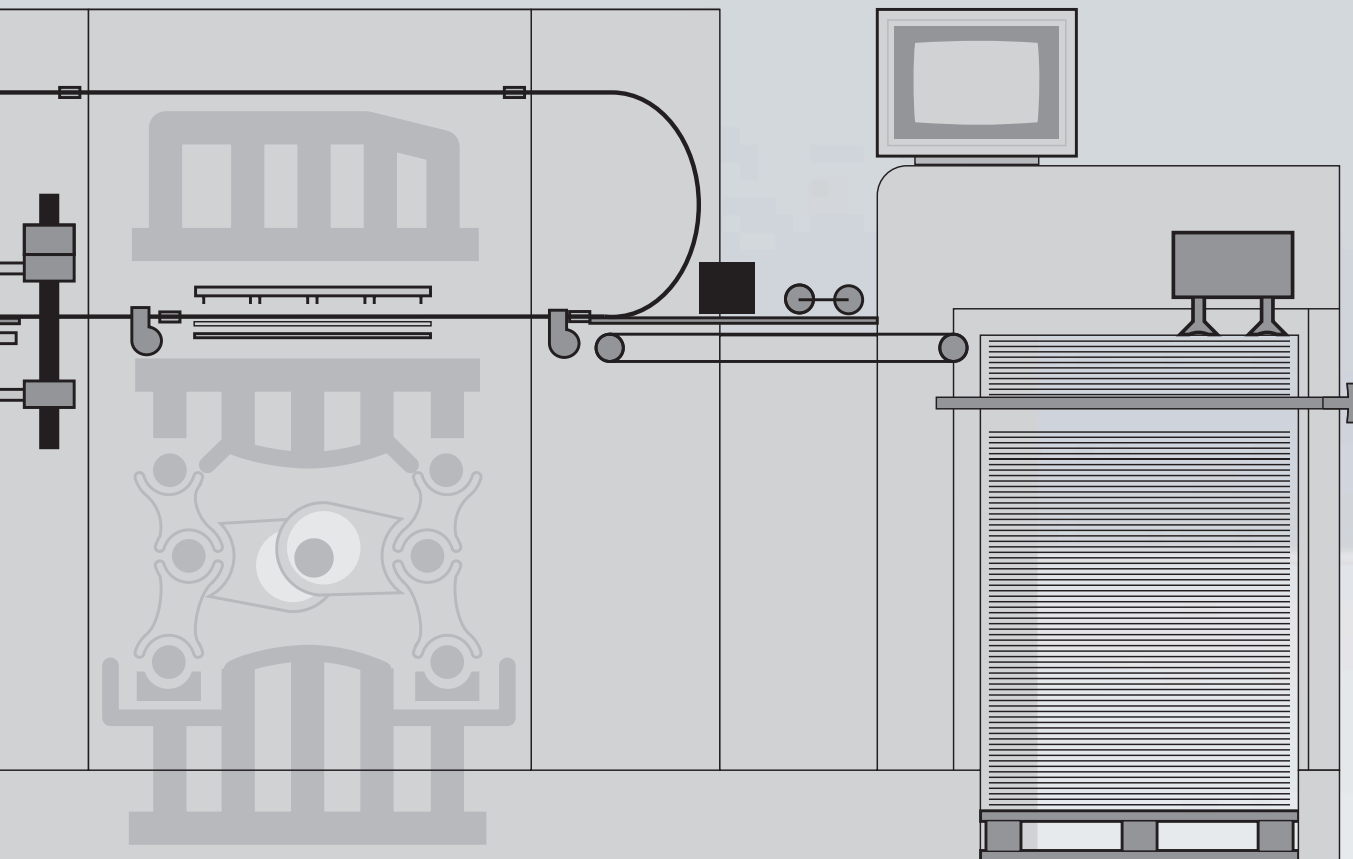

### Cutting Station

- Register system
- Motorized cutting pressure adjustment
- Pneumatic locking device for die-cutting chase and cutting plate
- Cutting plate fine adjustment
- Air cushion for easy cutting plate handling
- Quick lock chase
- Chase Changer (optional)

### Feed Table

- MasterSet (option)
  - optical sheet aligning system
- Suction belt table
- Central adjustment of rollers and brushes
- Sheet slow down device
- Register system

### Non-stop-Feeder

- Standard: manual non-stop
- Optional: auto-non-stop
- Feeder logistic (option)
- Suction head with quick positioning function
- Automatic lateral pile regulation
- Mechanical double sheet detection

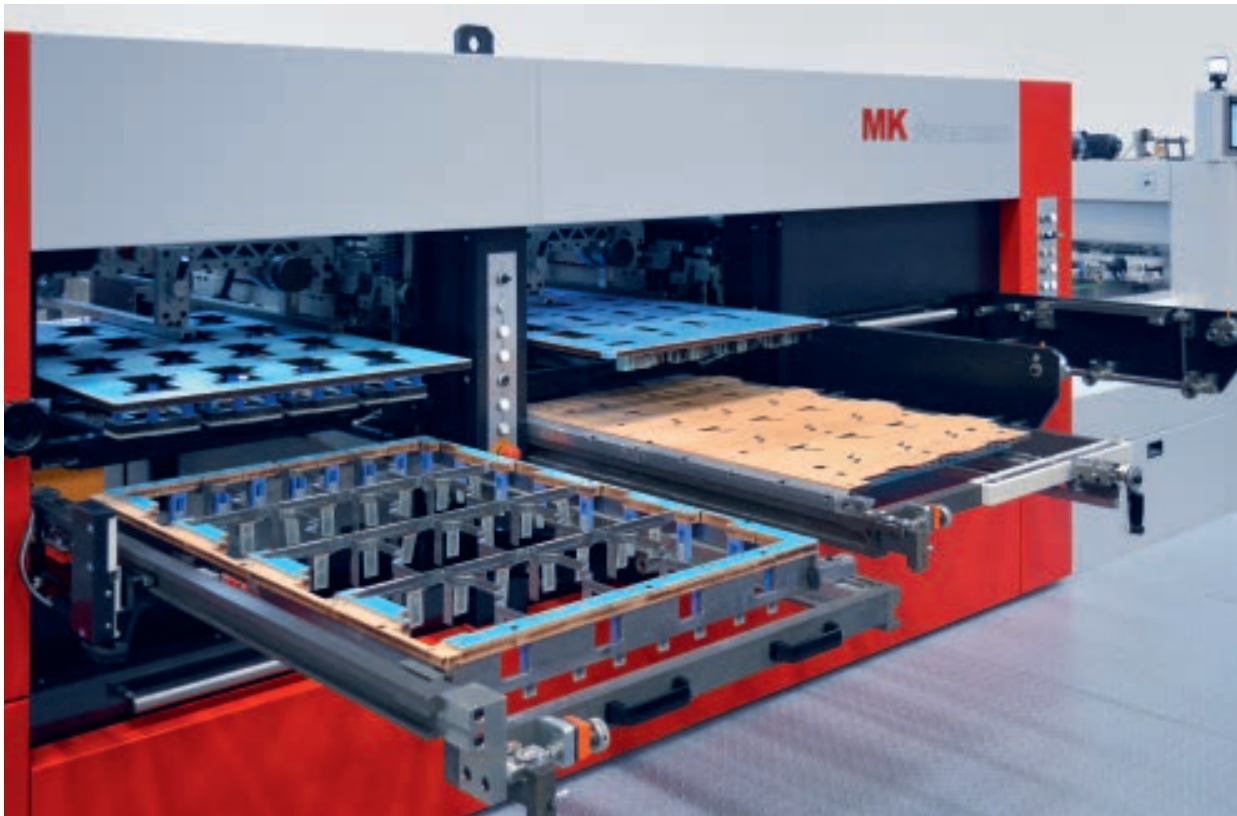

## Prinect.

### **The integration of postpress:**

- Automation and control of the entire manufacturing process for printed products
- Fast and transparent processes thanks to the accurate collection of production data
- Conversions and downtimes are greatly reduced
- Clear evaluation of machine efficiency in charts and tables

➔ [heidelberg.com/en/prinect](https://heidelberg.com/en/prinect)

## Service agreements.

### **For value retention and maximum performance:**

- Service agreements offer security and peace of mind, while at the same time providing you with the benefits of full cost control and simple administration
- Servicing by highly trained technicians
- Exclusive use of original service parts
- Protection of your machine investment
- Retention of a high resale value

➔ [heidelberg.com/en/service-agreements](https://heidelberg.com/en/service-agreements)



#### Liability for contents

The contents of this brochure have been prepared with great care. No warranty or liability is accepted for the correctness, completeness, or accuracy of the information. There is no guarantee that the customer will be able to achieve the values and numbers (e.g. relating to the function and performance of the machine) specified in the brochure. The information provided is based on ideal conditions and proper use of the machine. Achieving these values and numbers depends on a variety of factors and circumstances that are outside the control of Heidelberg as distributor and MK Masterwork as manufacturer (e.g. machine settings, technical conditions, ambient conditions, raw materials and supplies used, consumables used, standard of care and maintenance of the machine, expertise of the operator, etc.). They therefore constitute neither characteristics of the machine nor a guarantee. This brochure does not constitute a contractual offer and is solely for the purpose of providing (non-binding) information.



*distributed by*  
**HEIDELBERG**

**Heidelberg Druckmaschinen AG**  
Kurfürsten-Anlage 52-60  
69115 Heidelberg  
Germany  
Phone +49 6221 92-00  
Fax +49 6221 92-6999  
heidelberg.com