



The Peak Performance class. **Speedmaster XL 106.**



We accompany you. On your journey into the digital future.

For over 160 years, Heidelberg has prided itself on having a vital edge. That's why print shops all over the world trust our expertise and experience. Now they are also looking to us to help with the digital transformation of their business. As a reliable partner and technology pioneer, we create added value. We do so by providing printing systems that use Push to Stop technology for autonomous, top-quality production and data-supported services. Services that are paving the way to the Smart Print Shop – the digitally connected, intelligent, highly automated print shop of the future. For better decisions, higher productivity, and enhanced efficiency.

We laid the foundations 15 years ago by creating presses that were connected online and analyzing the data to boost performance and availability. Today, we offer you an entire ecosystem for digitizing value creation at print shops. As well as smart services such as predictive maintenance. You also benefit from trendsetting business models such as pay-per-outcome. Under this model, Heidelberg provides all the necessary equipment, software, consumables, and services. You simply pay for the number of sheets printed – for “productivity on demand” that can be flexibly adapted to your requirements. We call this “Simply Smart”.





Contents

04
Speedmaster XL 106

06
**Optimizing OEE increases
profitability**

08
Print site contracts

10
**The new Heidelberg User Experience
on the Speedmaster**

11
**The right dryer system for every
application**

16
Highlights for commercial printing

18
**Successful label and packaging
printing**

20
Artificial intelligence at Heidelberg

22
9 clear benefits

23
Your dialog with Heidelberg



6

CO₂
neutral

HEIDELBERG
Speedmaster

CO₂

HEIDELBERG
Speedmaster

The ultimate. Speedmaster XL 106.

Everyone is talking about Industry 4.0 or, reframed for the printing industry, Print Shop 4.0. Now is the time to seize the opportunity and develop business visions, scrutinize historical business models, and actively shape the necessary change processes.

The Speedmaster® XL 106 drupa 2020 generation from Heidelberg® is the most intelligent Speedmaster yet. It offers you innovative solutions specially tailored to the needs of classic commercial printing as well as complex packaging printing applications. The machines thus give you the best possible foundation from which to reinvent yourself for the future.

Experience undreamt-of performance. With Push to Stop, the efficiency of print production (OEE) can be raised to a level that has been difficult to achieve in the past. The new Intellistart® 3 assistance system revolutionizes your job changes with comprehensive, time-optimized automation.

Push to Stop and the implementation of artificial intelligence offer you a unique user experience (UX): autonomous and navigated printing across the entire printing process. The new Intelliline can be used to visualize the respective machine states.

Machine operation is now easier than ever – the new Heidelberg User Experience on the drupa 2020 generation of the Speedmaster will inspire you.

The ultimate Speedmaster – Speedmaster XL 106.

Greater success in the market for small and large printing companies.

Optimizing OEE increases your production profitability.

With the Speedmaster drupa 2020 generation, Heidelberg offers you the most highly automated and most intelligent Speedmaster yet. The smart machines in the series take advantage of the huge spectrum of digital possibilities for outstanding productivity and a significant increase in overall equipment effectiveness (OEE). The clear focus on operator-independent performance on the new Speedmaster raises Heidelberg's Push to Stop philosophy to a whole new level.

From the smart printing press to the smart print shop to the smart printing industry

Digitization is changing the printing industry. Heidelberg is making use across the board of the far-reaching optimization potential of digital technologies in the enhancement of its Speedmaster series with the objective of smart integration within the print shop and as part of a smart printing industry, where all stakeholders – print buyers, creatives, printing companies, service providers, and suppliers – are connected.

The future of industrial printing

Integrated communication along the entire process chain, paired with intelligent automation – this is the future of modern print production, whether for smaller businesses or large industrial printing companies. Intelligent production reduces complexity and speeds up processes autonomously. The key to this is digital connectivity with the Prinect® print and media workflow. Big data provides the relevant information for optimizing results and monitoring the processes on an ongoing basis. Heidelberg is setting standards in the area of the smart factory through the direct and complete integration of printing processes

in industrial applications, and is thus driving the intelligently controlled production.

OEE – the key performance indicator for productivity

Overall equipment effectiveness is an important key performance indicator for assessing how effectively a production system is operated in practice. It is made up of the factors of availability, performance, and quality. The average OEE across all format classes is currently around 20 percent, and even the Speedmaster XL 106 from the Push to Stop generation, with an average OEE of 27 percent, still offers considerable improvement potential, since the OEE that can realistically be achieved is much higher.

This is proven by Speedmaster presses operating with an OEE of 50 percent and up. The average productivity is expected to double in the coming years. With up to 90 million printed sheets a year, the first Speedmaster users are already showing what is possible.

Increasing overall equipment effectiveness (OEE)

Significant reduction of process-dependent and operator-dependent downtimes through Push to Stop.

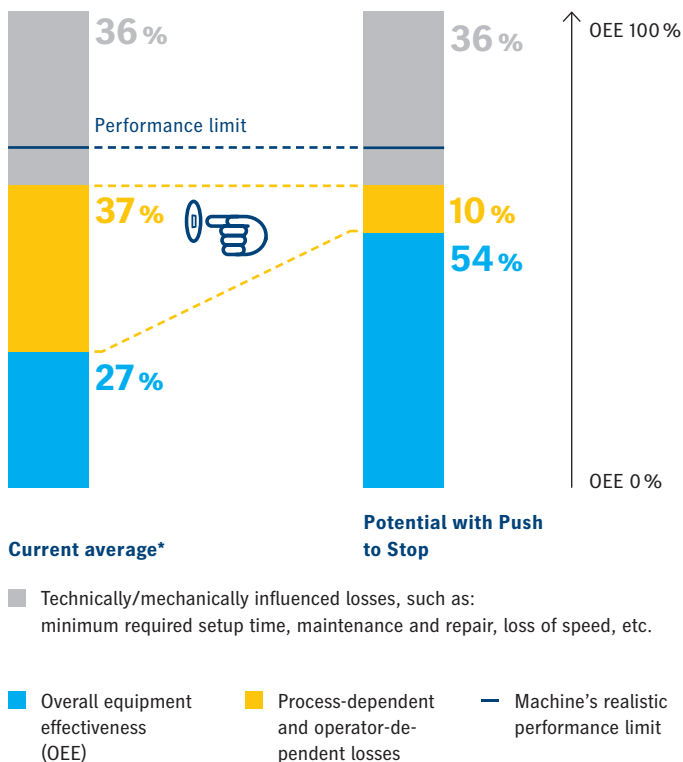

*OEE analysis 2020 using the example of a Speedmaster XL 106 and a run of 4,600 sheets

Exploiting potential: focusing on the yellow bar

In order to increase the OEE of the machines, existing improvement potential must be activated. Around half of this potential is tied to technical aspects (gray bar in graphic). However, technical improvements will not necessarily result in success – only if the organizational aspects are improved at the same time. The other half of the potential relates to processes and operators (yellow bar in graphic). This is precisely where Heidelberg concentrates its activities.

Process improvements and operator-independent solutions with Push to Stop have a direct effect on the OEE

Improvements that act on the yellow bar, in other words on the processes and operators, have a direct influence on the OEE. This is where the greatest potential lies. With Push to Stop, more extensive process automation, and intelligent assistance systems, the Speedmaster presses from the drupa 2020 generation enable even more comprehensive navigated and autonomous printing.

Speedmaster drupa 2020 generation: clear focus on operator-independent performance through intelligent automation.

- Close automation gaps
- Intelligent assistants for navigated printing
- Digital integration and use of digital data
- Potential of AI ensures optimal use of resources and highly effective production

The machine's intelligence minimizes the operator's influence on performance. Productivity is increased, processes are sped up, and become plannable and reproducible. The operator is navigated through the processes at a modern and attractive workstation, and in this way is better equipped to handle the greatly increased day-to-day requirements. Push to Stop on a new level – for optimized overall equipment effectiveness on all Speedmaster models.

A strong partnership for long-term success.

Print Site Contracts.

The Speedmaster XL 106 is entering new productivity dimensions with the drupa 2020 generation. It gives customers the ability to produce up to 90 million sheets per year, depending on their order structure. To fully exploit this enormous performance over the lifecycle of the Speedmaster, Heidelberg is offering a new kind of partnership with Print Site Contracts: through tailored solution packages and services, Heidelberg will actively help you to achieve a new level of performance. This will give you the freedom to successfully develop your business.

Contractual models as individual as your business

Print Site Contracts offer you everything you need to increase performance from a single source: from consumables and services, workflow and performance analytics including consulting services, to a complete production system for industrialized print production. You determine the areas where you want to drive performance, and the contractual model you want to use to achieve this. Heidelberg puts together a customized solution package and supports you during the implementation.

Reducing costs and complexity

Print Site Contracts unburden you of tasks that do not add value. How? Depending on the contractual model chosen, Heidelberg looks after topics such as optimization of production equipment, procurement and selection of consumables including warehousing and logistics, coordination of your agreed services, and planning of training measures for your employees. For you, this means significantly reduced process costs and administration and thus more time to focus on your customers and business.

Take advantage of the many ways of operating a Smart Print Shop with Push to Stop, and get the best from your Speedmaster XL 106. The only way to improve overall equipment effectiveness (OEE) is by activating existing optimization potential. The tailored solution packages of the Print Site Contracts enable you to maximize the performance of your Speedmaster XL 106.



Everything you need to increase your OEE.

You get this from a single source with Print Site Contracts – perfectly tailored to your individual needs.

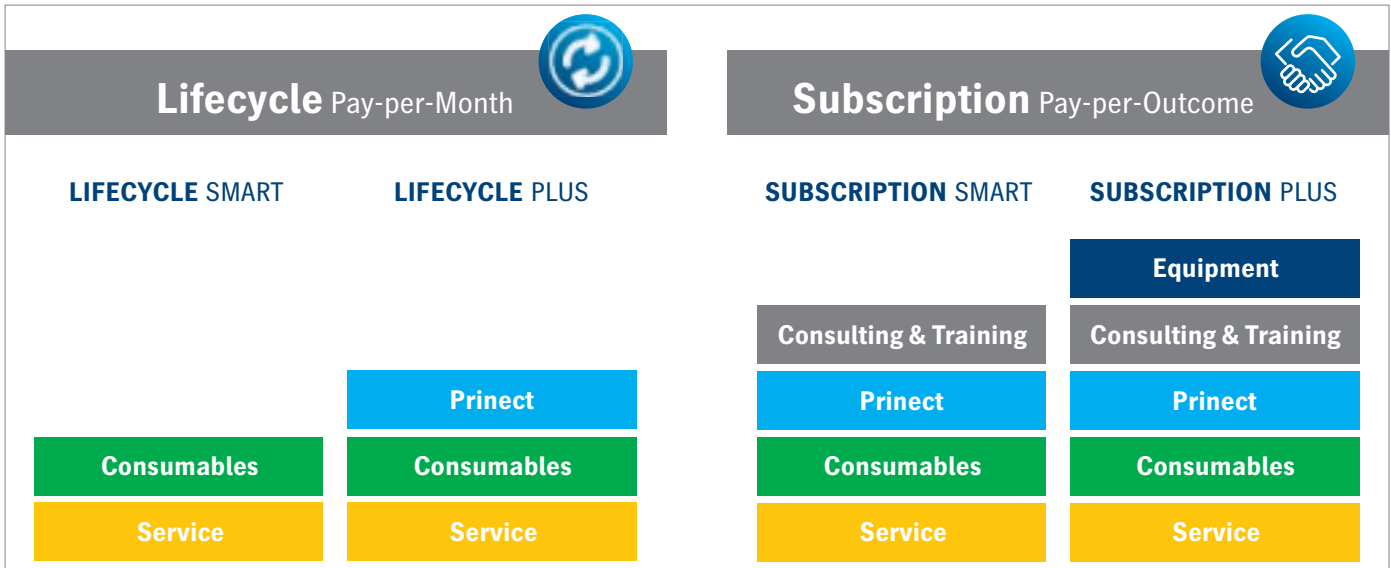

Gradually maximize performance and gain freedom.

Tailored solution packages range from flexibly combinable products and services at a monthly price to a smart production environment on a pay per outcome basis.

Lifecycle agreements – a compact package with a big impact

Perfectly coordinated consumables and complementary services from maintenance and repair to color management and application consulting ensure stable production with consistently high quality. At the same time, you benefit from reduced paper waste and shorter makeready times. Intelligent, data-based services such as predictive monitoring and performance analytics increase machine availability and provide transparency over your own performance level using production indicators. The Prinect workflow lets you digitize and automate manual steps as well as eliminate processes that do not add value.

Subscription agreements – productivity to the limit

Heidelberg Subscription allows you to take advantage of the benefits of a smart overall system with Push to Stop for maximum performance. Heidelberg provides the press, workflow, consumables, expertise, innovative services, and employee training. So that you can produce at maximum efficiency – without having to invest in your own equipment. By analyzing your KPIs, processes, and benchmark data, Heidelberg gives you clarity about where you have potential for improvement, and helps you to systematically close the gap to the front runners in the industry and increase your OEE.

Digital services – straightforward and available around the clock

The Heidelberg Assistant customer platform gives you access to a multitude of additional digital services at all times. This includes a vendor-managed inventory system and real-time information about the current performance of your company together with recommendations to increase performance. Digital Training makes it easy to access the expert knowledge available within Heidelberg. In addition, services such as predictive maintenance and monitoring help to increase your machines' availability.

Printing has never been so easy.

The new Heidelberg User Experience.

Immerse yourself in the new world of the Heidelberg User Experience (UX): completely rethought and clearer than ever before, it sets new standards for the user experience on the Speedmaster. The Prinect Press Center XL 3 with the new Speedmaster Operating System simplifies operation through one-of-a-kind navigation and new assistance systems, thus ensuring predictable results and increased performance.



A clear view for quality and precision

Heidelberg UX is the holistic and intuitive operation of all Heidelberg touch points. Intelligent assistants and a uniform user interface reduce complexity and simplify production processes.

Focus on you, the user

The Speedmaster Operating System with intuitive touch control turns the convenient control of the new Speedmaster into an experience. Settings can be called up with a click, and the scalable operation can be flexibly adjusted in accordance with the requirement profile. Intuitive operator guidance, innovative gesture control, and integrated help functions eliminate lengthy searches.

The Speedmaster Operating System delivers fast, simple and navigated use of all your machine's functionalities.

The most intelligent Speedmaster yet

Integrated assistance systems make your work easier. They look after routine tasks and ensure reproducible results.

Push to Stop – reliable performance through one-of-a-kind navigation and automation

For the first time, navigated printing with Push to Stop is possible on all Speedmaster machines. The patented Intellistart 3 defines all the steps required for the job change without any operator intervention and provides maximum transparency across all active and queued processes. Intelliguide® simulates the time-optimized sequence live and, if necessary, also includes the steps to be executed manually.

Everything at a glance

The Wallscreen XL completes the one-of-a-kind operator navigation for the highest performance demands. Intellirun, the new dynamic production view, shows the operator the right view at the right time, fully automatically, and provides intelligent information on the current production status. Intellirun thus not only supports you

For brilliantly fast jobs.

The right dryer system for every application.



Straight into postpress thanks to UV dryer systems

In times of short production runs and fast turnarounds, having the sheet arrive dry in the delivery for immediate forwarding to postpress is a huge advantage, particularly for commercial printers and web-to-print providers.

Whether as DryStar® UV, DryStar Combination UV with IR/hot air, or DryStar LED Pro, all systems have been specially developed for the Speedmaster XL 106 and adapted to the sheet travel, and in this way achieve the best drying results.

Saving energy with complete flexibility

The UV system is fully integrated into the operating concept of the press and precisely coordinated with its performance features. Regardless of whether based on UV lamps or UV LED technology, you achieve efficient energy use and complete flexibility thanks to the ability to select the position of the interdeck dryers.

Mixed-operation applications are also possible with both technologies, and are another way to further expand the range of applications.

Packaging and label printing

Until recently, UV printing in the label and packaging sector was still the preserve of qualified specialists. It was mainly used for high-quality finishings and special applications.

LED UV technology and new color and coating systems are opening up new perspectives for an ever-wider circle of users, all the way to label and packaging printing. Because the method's benefits are obvious: faster and more economical production with the same brilliant results. And with less use of resources and greater availability.

The various DryStar UV systems increase your range of services and the performance of your Speedmaster XL 106. You have greater flexibility in the choice of substrate available to you, since plastics and natural papers can also be used. You can offer your customers the entire range of special effects such as matt gloss effects, pearly luster effects, metallic effects, etc. and at the same time reduce the throughput times in your print shop.



DryStar LED Pro

Commercial printers and web-to-print providers benefit from instant drying and ozone-free production with LED diode technology, and the mercury-free and future-oriented technology also provides a way to set themselves apart from the competition. Optimum energy efficiency without any radiant heat in the press allows the best possible production conditions.

With the new DryStar LED Pro generation, the performance of the LED dryers has been further increased and the handling greatly simplified. DryStar LED Pro ensures a perfectly dry sheet through the precise focusing of the light and the optimum distance from the sheet travel. No power is consumed in standby mode (makeready times, washing times) thanks to the Instant On/Off system. The power consumption is further minimized by the timing of the diodes based on the format length. The Auto Format setting only activates those diodes actually required for the format width.

→ You can find more about technical data and facts here: [heidelberg.com/xl106/technical-data](https://www.heidelberg.com/xl106/technical-data)



The dynamic sheet brake gently decelerates the sheet under controlled conditions, and ensures perfect pile formation.



Heidelberg DryStar LED Pro – the new generation of high-performance LED dryers for outstanding drying results.

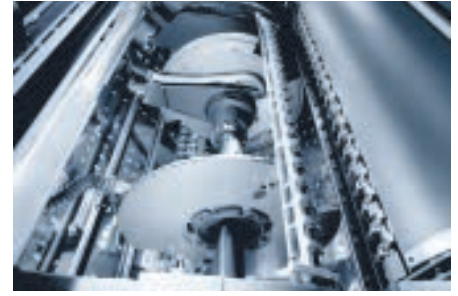

Controlled sheet transfer into the delivery area using suction segment disks.

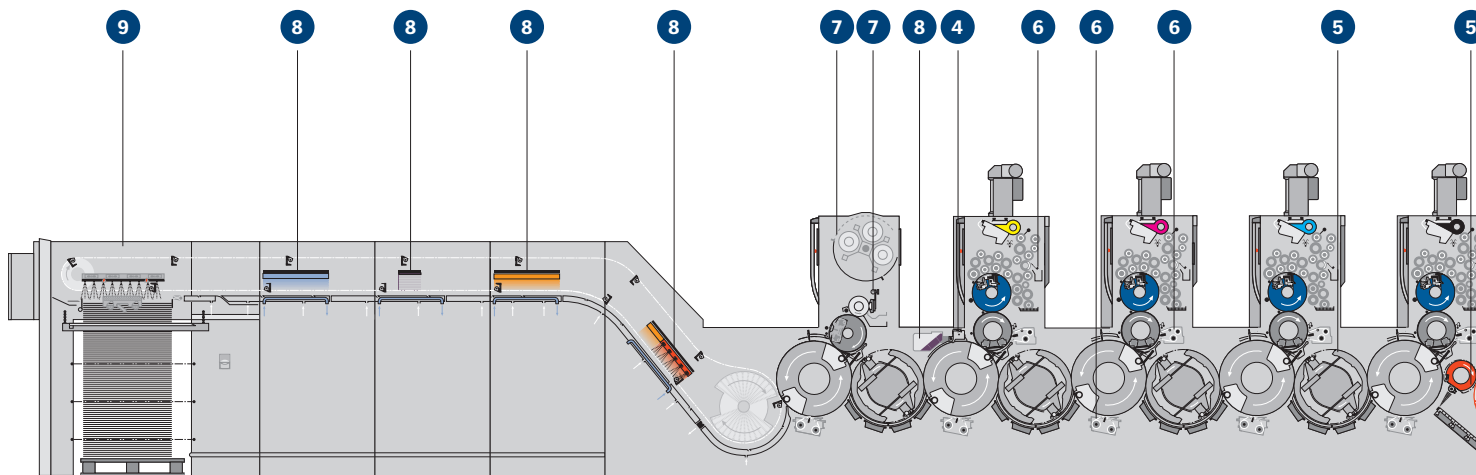

Speedmaster XL 106-8-P+L with DryStar LED. The press shown is a sample configuration. Some of the equipment features mentioned are optional.

1 Preset Plus feeder

- High-performance feeder with fully automatic presettings for all relevant format and air settings, for extremely short makeready times and steady sheet travel.

2 Fully automatic plate changer

- AutoPlate XL 3 offers fully automatic simultaneous plate change while washing blanket and impression cylinders at the same time for fast makeready.

3 Inking unit and dampening unit

- The Hycolor™ Multidrive enables the inking unit to be washed while other makeready processes are ongoing. Makeready times are considerably reduced, especially when ink changes are frequent.
- Hycolor Pro with motorized remote adjustment of the compression between the pan and metering rollers for a precise and stable dampening solution supply.

4 Prinect Inpress Control 3

- The integrated measurement system measures and controls register and color inline during production, and by so doing reduces makeready times and waste sheets.

5 Perfecting device and sheet travel

- The perfecting device with fully automatic adjustment guarantees precise registration and gentle sheet guidance across a wide range of substrates, from lightweight materials up to substrate thicknesses of 0.8 mm (0.031 in).
- The variable AirTransfer system with dynamic sheet spacing control provides contact-free sheet travel based on a characteristic profile, ensuring outstanding print quality in straight printing and perfecting.

6 Washup devices

- Program-controlled blanket washup devices for blanket and impression cylinders with extremely short washing times combined with outstanding washing results.
- Wash Assistant enables the automatic selection of the optimum washup program for the inking unit and blanket and impression cylinders based on the degree of soiling.

7 Coating unit

- The high-end chamber blade system ensures reproducible and stable inline finishing across the entire run.
- AutoPlate Coating Pro for automatic/tool-free coating plate changes and Multi Loader system for automated screen roller changes for the shortest makeready times.
- Fully automatic impression cylinder washup device for inks and coatings with extremely short washing times.

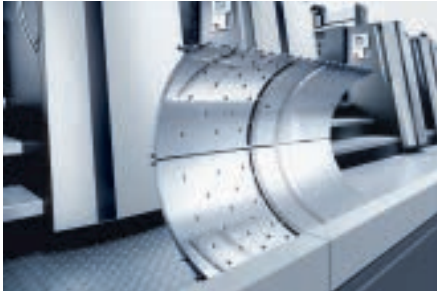

Venturi Air Jet technology for contact-free sheet transfer after the perfecting stage.



Perfecting device with fully automatic adjustment for precise registration, even at top speeds.



Simultaneous plate change with AutoPlate XL 3, while washing blanket and impression cylinders at the same time.

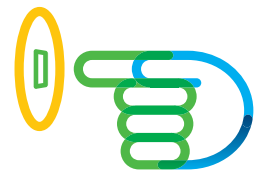
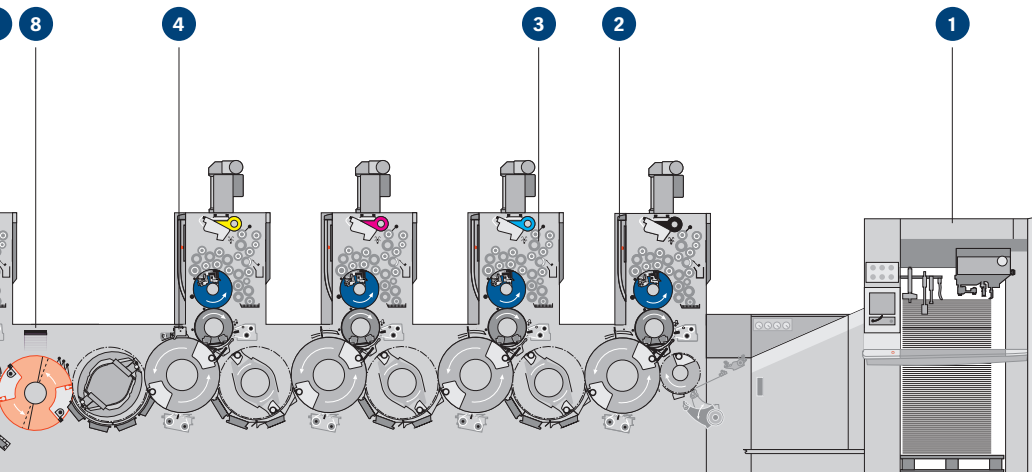

Push to Stop
The key to the
Smart Print Shop.

8 Dryer systems

- DryStar high-end drying systems for conventional ink and coating applications as well as for UV and LED UV achieve outstanding drying results at top speeds.

9 Preset Plus delivery

- High-performance delivery with comprehensive, material-specific presettings enables piles with neatly aligned edges.
- Directly driven, presettable dynamic sheet brake decelerates the sheet in a safe and controlled manner. Settings are automatic as the preset data are used.
- Fully automatic non-stop system with movable belt table for reliable pile separation and uninterrupted production.

+ CutStar 106

- The shortgrain roll sheeter combines the cost benefits of roll-fed stock with the flexibility of sheetfed offset printing for stable production speeds for thin materials.

+ FoilStar 106

- The FoilStar® generation III enables inline processing of up to six cold-foil rolls in one module. Cyclic multi-web operation with up to four cold-foil rolls is possible as an option, and can further significantly reduce material usage.

→ You can find more about the details of your Speedmaster here: heidelberg.com/en/xl106



Modern working environment on the Princt Press Center XL 3 with 24-inch multi touchscreen and LED standard daylight lamp for optimal sheet coordination.



Intelliline offers one-of-a-kind assistance and transparency at the machine and navigates you through any manual steps required.

during the automated job change, but also throughout production. For the first time, all production steps are supported by an up-to-date overall view. The feeder display also shows important job information for optimal integration of the helper.

The new **Intelliline LED-based navigation support** extends this logic to the machine. The resulting expansion of the Intelliguide, Intellistart 3, and Intellirun process displays provides a color visualization of the unit status on all printing, coating, and drying units on the operator and drive sides. You can keep an eye on everything at all times and are prompted when intervention is required.

What this means is a new era of navigated and autonomous printing with Push to Stop. Uninterrupted productivity with the fully automated job change – from the last sheet to the first good sheet and the start of production.

Perfect data and color management with Princt

The Princt Press Center® XL 3 links the printing press to the print shop's Princt workflow. Job data can be transferred and also made available in an automatically defined sequence. The production data is returned fully automatically. This enables you to benefit from excellent data management, one-of-a-kind presets, up-to-date production data, and informative reports.

The Princt Inpress Control 3 inline color measurement system stands for high productivity. The powerful Princt Axis Control™ and the Princt Image Control® 3, which measures the entire print image, also offer you optimal, reproducible color stability and minimum paper waste. All color measurement systems are perfectly integrated into the workflow via the central color database and provide automated color reports.

Simply – fast – reliable: the new Heidelberg UX on the Speedmaster XL 106

Experience the Heidelberg UX on the Speedmaster XL 106 also. Every time you operate a component you are experiencing the Peak Performance concept. From the seamlessly ergonomic design, to the pioneering touchscreen control panels, the simple handling of the washup devices to the unique preset functionality, the Speedmaster XL 106 delivers an unparalleled user experience.

Machine and market.

Highlights for commercial printing.

In commercial printing, the trend towards small runs and print-on-demand jobs continues unabated. Stock volumes are reduced due to more frequent updates, different versions for specific target groups, seasonal designs, campaigns and individual customer adaptations – all reasons why the number of job changes is constantly increasing. We are responding to this trend with our Push to Stop concept for navigated and autonomous printing.

One machine for all runs

The Speedmaster XL 106 is the right machine for frequent job changes. But its constantly high quality with steady production speeds of 18,000 sheets per hour in straight printing or perfecting mode is also impressive in longer runs.

The intelligent interaction of the automation components enables you to achieve the cost effective production of all commercial printing applications – for large or small runs. A central component is the patented, process and job-oriented Intellistart 3 assistance system.

Reaching the goal quickly and economically with navigation

Intellistart 3 calculates the quickest process route and navigates the operator through the job change. Automated processes are parallelized where possible and autonomously completed in a logical sequence. Autonomous printing not only automates the makeready processes, but also quality monitoring within the machine during setup and production.

Heidelberg technology for fast plate changes

AutoPlate Pro changes the plates fully automatically using a staggered approach. AutoPlate XL 3 changes all plates simultaneously in less than a minute. Both systems are integrated into the Intellistart workflow for autonomous printing.

Precise and steady dampening solution supply

With Hycolor Pro, Heidelberg enables remote adjustment of the compression between the pan and metering rollers from the Prinect Press Center XL 3 for the first time – for a precise and steady dampening solution supply.

Automation saves valuable time

Presetting of the entire machine for a new substrate is done fully automatically using preset values from a database containing the air settings for popular substrates. Color Fast Solution automatically enables fast inking-up with the least possible paper waste.

Color Assistant Pro not only provides fully automated monitoring of the ink fountain liner, but also adapts the ink presetting accordingly.

Hycolor Multidrive washes the inking unit at the same time as the blanket and impression cylinders, again fully automatically. The Wash Assistant has determined the optimum washup program for efficient washing for each area in advance.

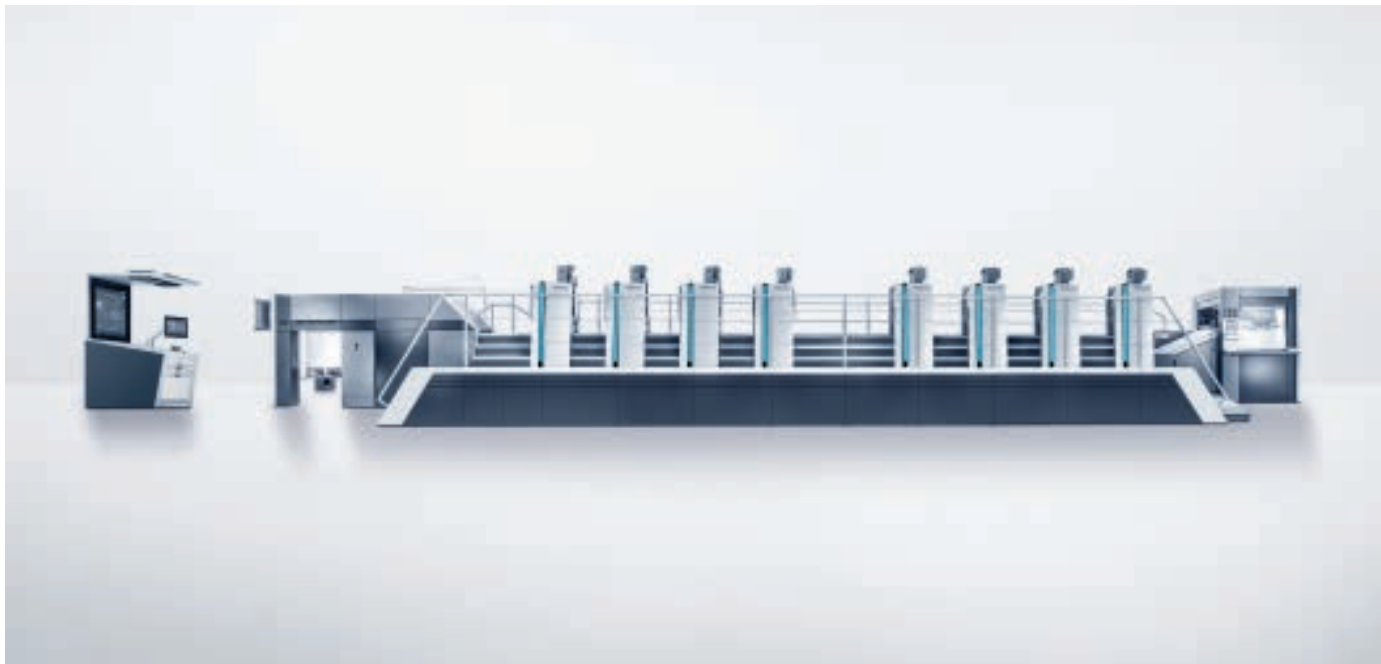

Increased productivity through automation

The consistent reduction and elimination of manual touch-points through automation reduces your Speedmaster's downtimes and increases your productivity.

The fully automatic non-stop delivery with movable belt table enables continuous, uninterrupted production with longer runs. With the CutStar® 106 shortgrain roll sheeter you benefit from the cost advantages of roll-fed stock and the flexibility of sheetfed offset printing. It processes grammages between 40 and 300 g/m² and web widths from 480 to 1,060 millimeters (18.90 in x 41.73 in).

Everything under control – just like that

Time and paper waste are two important factors, and ones that require close attention. Prinect Inpress Control 3 automatically measures and controls color and register on the fly and at any speed. The measuring unit integrated into the printing press recognizes scale colors, spot colors, and registers in the print control strip. Any necessary corrections are forwarded directly to the Prinect Press Center XL 3 control station for adjustment and automatically carried out.

In combination with Prinect Inpress Control 3, Quality Assist automatically switches to production mode from job change mode once the defined quality requirements are met.

Excellence on both sides

The triple-drum perfecting system with fully automatic switchover enables flexible production in straight printing or in perfecting mode for lightweight materials up to substrate thicknesses of 0.8 mm (0.031 in). The variable AirTransfer system with dynamic sheet spacing control provides contact-free sheet travel based on a characteristic profile, ensuring outstanding print quality in straight printing and perfecting.

The TransferJacket Blue and PerfectJacket® cylinder jackets guarantee optimal print quality in straight printing and perfecting. If necessary, you can replace the PerfectJacket quickly and reliably using the quick-change system.

Machine and market.

Successful label and packaging printing

Our machines are world leaders in packaging and label printing when it comes to our overall portfolio. The Speedmaster XL 106 plays a decisive part in this success. It is the ideal solution for packaging and label printers. Artificial intelligence and new assistance systems help to take the operator out of the productivity equation.

Individuality, flexibility, and intelligent systems are the core messages in the digital transformation of existing structures in packaging and label printing. Short delivery times and low unit quantities – Push to Stop is the key to maximum productivity. With stable production speeds of 18,000 sheets an hour, the press is an especially cost-effective solution for highly industrialized packaging and label printing.

Parallel makeready processes in packaging and label printing increase the productivity of the Speedmaster

The intelligent interaction of the automation components enables cost-effective production of all products in packaging and label printing.

A central component is the Intellistart 3 assistance system which, like a navigation system, shows you the shortest route to your goal. For each job change, Intellistart 3 creates an optimal workflow sequence taking into consideration all processes that can be executed in parallel. Order preparation and data transfer are ideally performed while the preceding job is still in production. During the makeready process, the operators are kept informed about the sequence and the respective status of the processes at all times by Intelliguide and Process View. They are made aware of any necessary manual activities in order to avoid unproductive times.

Print production can thus achieve a level of efficiency that was previously difficult to reach. Processes run independently of the operating personnel, and the error rate due to manual interventions drops.

Automatic plate change systems for fast job changes

You can choose between different plate change systems: AutoPlate Pro changes the plates fully automatically using a staggered approach. AutoPlate XL 3 changes all the plates simultaneously in less than a minute. Automated plate changing systems are also available for the coating unit, with AutoPlate Coating and AutoPlate Coating Pro. They are the ideal complement in the coating unit to the Multi Loader screen roller storage system for automated and fast screen roller changes, and to the new impression cylinder washup device for dispersion and UV coatings.

Even long runs without interruption

Automatic non-stop plate changes in the feeder and delivery at maximum speed save you valuable time and reduce paper waste. Various systems are available for automatic feeder loading and for dispatch of the printed plates at the delivery, and are fully integrated into the machine controller. Thus you benefit from seamlessly optimized production.

Economical from the roll

The CutStar 106 shortgrain roll sheeter is the ideal complement for processing thin label papers or foils (e.g. in-mold labels) at high production speed. It processes roll-fed stock between 40 g/m² and 300 g/m² and web widths from 480 to 1,060 millimeters (18.90 in x 41.73 in). It is characterized by short makeready times and a high level of automation.

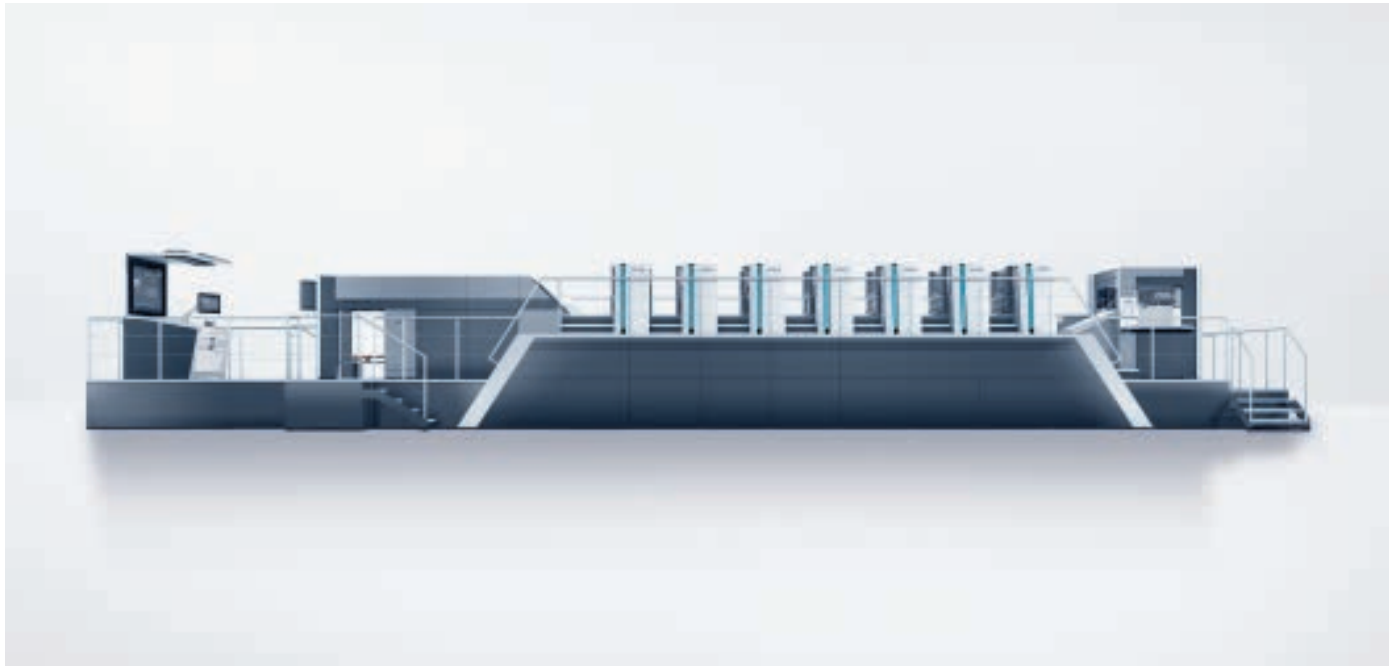

Good sheets, pile by pile

The paper waste ejection feature in the delivery automatically rejects sheets detected as defective during the production run – and only the relevant sheets, precisely in accordance with the quality specifications.

For quick and easy ink changes

Cleaning the foil-lined ink fountain is quick and easy. There is no need to calibrate the ink zones. Color Assistant Pro automatically monitors the status of the ink fountain liner and automatically adapts the ink metering for fast inking-up.

Intelligent and fast washup

With Hycolor Multidrive, the inking unit can be washed while other makeready processes such as changing the printing and coating plates are ongoing. The Wash Assistant automatically determines the optimal wash-up program for efficient washing of the inking unit and blanket and impression cylinders.

Precise and steady dampening solution supply

On the Prinect Press Center XL 3, you can adjust the compression between the pan and metering rollers remotely using Hycolor Pro – for a precise and stable dampening solution supply.

Everything under control – just like that

Time and paper waste are two important factors, and ones that require close attention. Prinect Inpress Control 3 automatically measures and controls color and register on the fly – and at all speeds. The measuring unit integrated into the printing press recognizes scale colors, spot colors, and registers in the print control strip colorimetrically.

Prinect Image Control 3 offers a real alternative thanks to measurement that covers the whole print image while at the same time providing automatic online control for all printing units. Even opaque white can be optimally controlled.

Quality control from the first sheet to the last

Prinect Inspection Control 3 checks each sheet for hickeys, material defects, ink splashes, scumming, and so on using two high-resolution color cameras in the coating unit to prevent follow-up costs. The optimized blower air-assisted sheet guide ensures a high inspection quality right up to the trailing sheet edge. PDF verification permits automatic comparison of the printed sheet and the PDF for the job. Prinect Inspection Control 3 is ideal for combination with the automatic waste ejection system in the delivery – for a pile with no defects.

Automatic paper stretch compensation

This automatic paper stretch compensation Prinect APSC calculates the paper distortion to be expected based on the paper type and color distribution, and compensates for it during platesetting. The setup time is significantly reduced, since manual interventions for optimal registration are reduced.

Smart Print Shop of the future.

Artificial intelligence at Heidelberg.

The comprehensive digitization is currently bringing about fundamental changes in large segments of our daily life and work. The digitization poses a major challenge for industrial companies, as well as for the printing industry and Heidelberg.

Digitization offers the printing industry many opportunities. New processes are catalysts for greater productivity. Intelligent machines complete print jobs fully autonomously. Push to Stop is becoming reality, and print shops are transforming into Smart Print Shops.

Solutions such as Push to Stop for optimizing makeready times and OEE, or service support through automated delivery of consumables, are already preparing printing companies for the digital future.

Focus on the digital workflow

Prinect, the print and media workflow from Heidelberg, is at the heart of industrial print production. It enables integrated processes to be implemented along the entire value chain. This gives rise to a stable system comprising a press, workflow, application technology, consumables, and services. Data plays a key role in this process. You can only optimize your processes and make transparent decisions if you have all the information at hand in real time.

Artificial intelligence in print production

Artificial intelligence (AI) simplifies workflows, enables more accurate prognoses, and creates new, data-based business models. It permits faster decisions on the basis of a wide range of data and real-time information as well as prognoses beyond human capabilities.

In the smart production environment, a defined algorithm makes decisions much more efficiently and effectively than a human about the orders of plates, ink curves, washup programs, dryer settings, powder quantities, etc. Artificial intelligence becomes the key to increased competitiveness and the ability to adapt to changes in the market.

Integrated machine sensors provide a continuous stream of information. Evaluating this correctly is what turns “big data” into added value. To this end, the Heidelberg Remote Services network links over 10,000 machines and 15,000 software products into an industrial Internet of Things. This network is key to the quality of the individual service products and productivity recommendations. Integrated communication along the entire process chain, combined with intelligent automation, represents the future of industrial digital print production.



Continuous process optimization through artificial intelligence

Preset 2.0 and the intelligent systems Wash Assistant, Powder Assistant, Color Assistant Pro reduce manual interventions to a minimum.

The future belongs to intelligent systems

We at Heidelberg are intimately acquainted with print production methods and are putting this knowledge to use to shape Push to Stop in line with market requirements. Artificial intelligence from Heidelberg means that the presets for production no longer need to be defined by an expert team, they can be variably adapted by intelligent algorithms. During production, all settings and quality measurements are first collected and then automatically evaluated. Regular data patterns are identified and their effect on the production result is learned. The insights are used to optimize the efficiency and quality of upcoming production.

Process optimization with AI – Preset 2.0

Artificial intelligence makes decisions independently and learns continuously. It uses the data pool of the installed base to detect patterns, identify potential, and generate basic settings (default values) that increase the efficiency of print production – autonomously and without human influence. Optimized settings for individual machines can also be made on the basis of reference machines, or basic settings optimized for a large machine pool. For **Preset 2.0**, data from over 600,000 print jobs was analyzed using an algorithm and continuously improved. An improvement in productivity of up to five percent is possible on the basis of the new characteristic curves and settings alone.

Self-learning Color Assistant Pro

The **Color Assistant Pro** software permits continuous, precise optimization of the ink presetting on the press and absolute precision during ink metering. The ink zones are automatically adapted to the status of the ink fountain liner. The intelligent algorithm learns autonomously by performing target/actual comparisons of the settings and automatically specifies new ink zone characteristic curves after a job finishes. Color Assistant Pro avoids mistakes due to manual handling and achieves increased performance independently of the operator.

Assistance systems for efficient, autonomous processes

The innovative **Powder Assistant** achieves consistent print quality with less powder and therefore also less cleaning time. The intelligent tool independently selects the optimal presetting based on the color assignment and substrate.

Up to now, the operator decided subjectively which washup program to use. With **Wash Assistant**, the machine makes the decision. The intelligent Wash Assistant chooses the objective best washup program based on the ink, substrate, and other parameters.

Leader in the printing process.

9 clear benefits.

Makeready



Plate change with AutoPlate XL 3 in under

1 minute.

Simultaneous makeready processes with Hycolor Multidrive – changing plates, washing inking unit, blanket and impression cylinders – back printing packagings **5 minutes** after the last sheet in a run.

0 min.

additional makeready time due to fully automated air settings when changing substrates using characteristic profiles.

Productivity



Waste ejection system in the delivery automatically sorts out sheets detected as incorrect during production – **no subsequent quality inspection.**

Run printing before the

30 sheet

with **Prinect Inpress Control 3** and **Smart Mode.**

Improvement of the **OEE** through reduction of process-dependent and operator-dependent downtimes – operator-independent performance through **intelligent automation.**

User friendliness

0 min.

manual cleaning time thanks to the fully automatic washup device in the coating unit.



Autonomous printing

from the last to the first good sheet, fully automated job change – the ultimate solution of **navigated printing.**

 **1 click**

The **new Heidelberg User Experience on the Speedmaster**
The integrated Speedmaster Operating System with intuitive touch operating concept.

Simply get in touch. Your dialog with Heidelberg.



We hope this brochure has inspired you. Our aim is to make you even more successful in the future, so feel free to contact us with your questions and suggestions. We're only ever an e-mail or phone call away.

We look forward to hearing from you!

Whether you're just curious or have specific things you'd like to ask, simply send an e-mail with your questions, requests, or comments to

➔ info@heidelberg.com

or use our contact form at

➔ heidelberg.com/info

If you prefer to use the phone, your local contact is waiting to hear from you. You'll find the phone number you need on the web page for your country.

➔ heidelberg.com/contact



Your direct access to the digital world of Heidelberg, including our international distributors, newsletter registration options, and social media channels. Simply use your smartphone to scan the QR code. heidelberg.com/dialogue

Heidelberger Druckmaschinen AG

Kurfuersten-Anlage 52 – 60

69115 Heidelberg

Germany

Phone +49 6221 92-00

Fax +49 6221 92-6999

heidelberg.com

Publishing Information

Printed in: 03/20

Photographs: Heidelberger Druckmaschinen AG

Platemaking: Suprasetter

Printing: Speedmaster

Finishing: Stahlfolder

Paper: Magno Satin Sappi Europe

Consumables: Saphira

Fonts: Heidelberg Antiqua ML, Heidelberg Gothic ML

Printed in Germany

Trademarks

Heidelberg, the Heidelberg logotype, CutStar, DryStar, FoilStar, Hycolor, Intelliguide, Intellistart, PerfectJacket, Prinect, Prinect Axis Control, Prinect Image Control, Prinect Press Center, Saphira, Speedmaster, Stahlfolder and Suprasetter are registered trademarks of Heidelberger Druckmaschinen AG in the U.S. and other countries. All other trademarks are property of their respective owners.

For details on the emissions of the XL 106, please visit us at heidelberg.com/emissiondetails

Subject to technical modifications and other changes.

Liability for contents

The contents of this brochure have been prepared with great care. No warranty or liability is accepted for the correctness, completeness, or accuracy of the information. There is no guarantee that the customer will be able to achieve the values and numbers (e.g. relating to the function and performance of the machine and the software) specified in the brochure. The information provided is based on ideal conditions and proper use of the machine and the software. Achieving these values and numbers depends on a variety of factors and circumstances that are outside the control of Heidelberg (e.g. machine settings, technical conditions, ambient conditions, raw materials and supplies used, consumables used, standard of care and maintenance of the machine, expertise of the operator, meeting the respective system requirements, etc.). They therefore constitute neither characteristics of the machine or the software nor a guarantee. This brochure does not constitute a contractual offer and is solely for the purpose of providing (non-binding) information.



sappi | Magno